

PROTECTION RELAY : RP2 + 1



OPERATING PRINCIPLE:

The contact protection relay is used as interface between the level detector and the resistance signal.

Its advantages are to preserve the detector's contacts by impressing them very lower currents and tensions and to ensure a galvanic insulation.

Depending on the connection type, it allows the following functions :

- auto-emptying or -filling-up + high or low alarm.

Or

- 2 functions : high and low alarm.

TECHNICAL DATA :

- * Mains voltage : 24, 115, 230 V AC or 24 VDC
- * Power consumption : approx. 3 VA
- * Output relay : 2 change-over contacts 3A /230V/50-60 Hz
- * Status signalling : switched-on diode if relay excited
- * Housing : makrolon
- * Ingress protection : housing : IP40
terminal : IP20
- * Ambient temperature : -20°C to + 60°C

DIMENSIONS

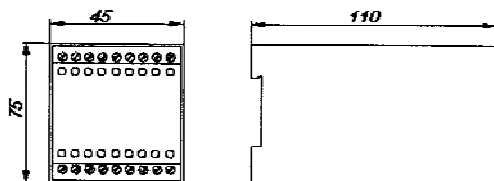

Mounting on DIN 46277 and DIN EN 50022 rail

CONFIGURATION FOR :

Auto-emptying or -filling-up +
high or low alarm

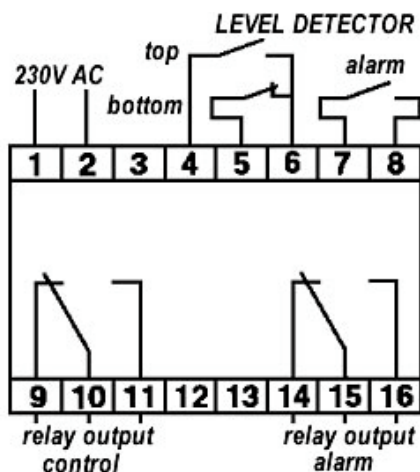

CONFIGURATION FOR :

2 functions : high or low alarm

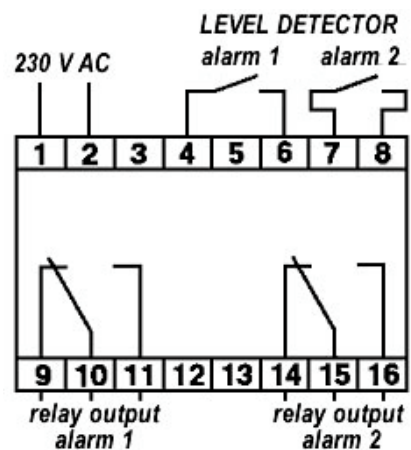

AMPLIFIER SEPARATOR

TYPE : MK13-222Ex0-R/230 VAC



Approval Ex N° PTB 00 ATEX 2033



ACCOMMODATING CONNECTION:

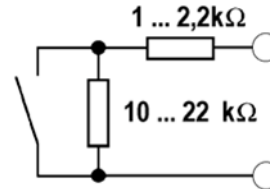

OPERATING VOLTAGE U_b : 196...253 V AC

- Mains frequency.....48...62 Hz
- Current / power consumption.....< 30 mA
- Galvanic separation between input and output circuits and compared with the voltage for 250 V
- Testing voltage.....2,5 kV
- Max. values:
 - voltage at no-load conditions U_o ≤ 14 V
 - short-circuit current I_k ≤ 22 mA
- External inductances / capacitances:
 - (EEx ia) IIB...
 - (EEx ia) IIC...

Input circuits

According to EN 50227 (NAMUR) in inherent safety according to EN 5002
Service values:

- Voltage.....8 V
- Current.....8 mA
- Switching threshold.....1,55 mA
- Hysteresis.....typ. 0,2 mA
- Cables parting protection threshold.....< 0,1 mA
- Short-circuits protection threshold.....> 6,0 mA

Output circuits

- 2 outputs for each relay (1 N.O. contact)
- Switching voltage.....< 205 V AC / 120 V DC
 - Switching current for each output.....< 2 A
 - Switching power for each output.....< 500 VA / 60 W
 - Switching frequency.....< 10 Hz
 - Contact material.....alloy Ag + 3 μ m Au

LED display

- Switching state / normal display.....2x yellow / red (bicolor LED)
- Operating voltage.....green

Modular terminal box

- 12 poles, width 18 mm, polycarbonate / ABS, combustion class V-O according to UL 94
- Mounting.....panel mounting or locked onto a symmetrical DIN 50022 rail
 - Connection.....flat sockets with washers
 - Joining section.....< 2 x 2,5 mm² or 2 x 1,5 mm² with sockets
 - Operating temperature range.....-25°...+60°
 - Ingress protection.....IP 20

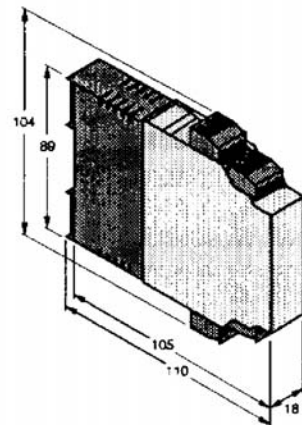

AMPLIFIER SEPARATOR

TYPE : MK13-222Ex0-R/230 VAC

OPERATING PRINCIPLE:

MK13-222Ex0-R are bi-channels amplifiers separators with inherent safety input circuits. Detectors or free-voltage contacts can be connected to these amplifiers according to EN 60947-5-6 (NAMUR). Six switches in front face of the amplifier authorize the function activation for each channel (operative or inoperative function) and wire break and short-circuits control. If using mechanical contacts, cable parting and short-circuits control must be disabled, or the contact must be equipped with resistors (the accommodating connection is displayed above). The green LED displays the operating voltage. In case of failure in the input circuit, if the detector's circuit control is operating, the two bicolor LED become red. In this case, the corresponding output relay is de-energized.

- Bi-channels amplifiers separators
- Inherent safety input circuits (EEx ia) IIC
- Galvanic separation between input and output circuits and compared with the mains voltage
- Input circuits control for cable parting and short-circuits (can be activated or deactivated)
- Two outputs for each relay and for each a N.O. contact
- Programmable output in operative or inoperative function

INSTALLATION HINTS:

The device can be snapped onto a rail (EN50022) or panel mounted. Devices of the same type can directly be mounted on one or another. An adequate heat dissipation must be ensured. Mounting and installation must be done according to valid directives. The carriage type terminals are encoded and can only be plugged in the planned appliance plugs. The encodage can not be modified or damaged. The output circuits' terminals can not be removed or plugged in when the relays are commutated. The device must be protected enough against dust, dirt, moisture and other occasional environment influences, also against mechanical damage risks, unauthorized modifications and accidental physical contact.

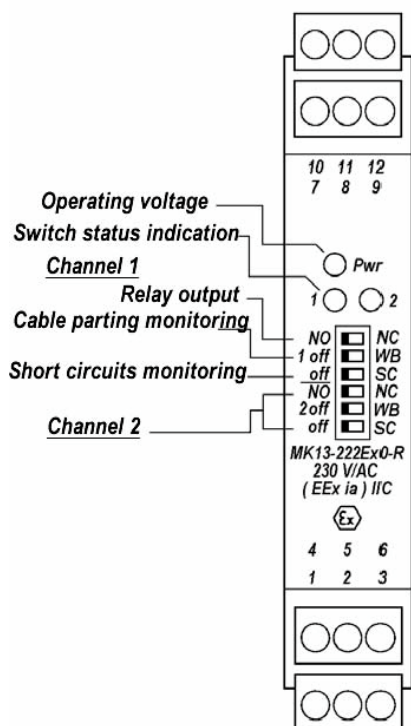

ADJUSTING:

The input circuit function and cable parting and / or short-circuits control can be separately defined for each channel by means of a switch in front face.

